

APPLICATION

- Access door for installation into grease ducts
- This door meets or exceeds requirements of all mechanical codes

FEATURES

- Bolt in unit easily installed into existing ductwork
- Duct cutout template included
- No bolts penetrate to the interior of the duct
- Two handles for easy removal and installation



SKU: **GDD**
DUCT DOOR
 FOR GREASE DUCTS

DIMENSIONS AND APPEARANCE

>> CLICK TO VIEW ADDITIONAL DETAILS AND PRICING <<

MODEL NO.	PANEL OUTSIDE DIMENSION		PANEL HEIGHT	STUD HEIGHT	HOLE SIZE Inches (mm)		MTG STUDS (NUTS)
	A	B	C	D	E	F	
FGGD0712	10" (254mm)	15" (381mm)	.5" (13mm)	1" (25mm)	7" (178mm)	12" (305mm)	6
FGGD720	10" (254mm)	23" (584mm)	.5" (13mm)	1" (25mm)	7" (178mm)	20" (508mm)	10
FGGD1212	15" (381mm)	15" (381mm)	.5" (13mm)	1" (25mm)	12" (305mm)	12" (305mm)	8
FGGD1220	15" (381mm)	23" (584mm)	.5" (13mm)	1" (25mm)	12" (305mm)	20" (508mm)	14
FGGD1620	19" (483mm)	23" (584mm)	.5" (13mm)	1" (25mm)	16" (406mm)	20" (508mm)	16
FGGD2020	23" (584mm)	23" (584mm)	.5" (13mm)	1" (25mm)	20" (508mm)	20" (508mm)	16

For detailed specifications see submittal sheet

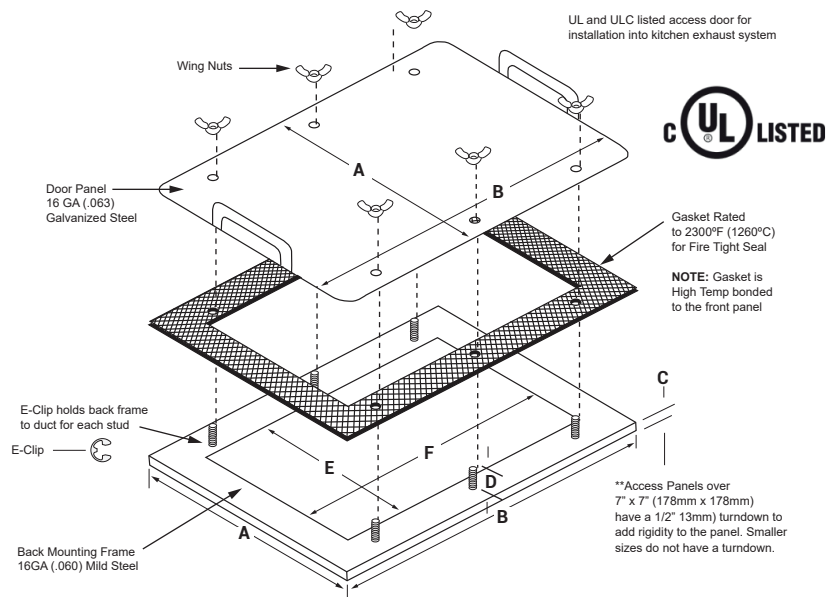

For a complete list of options visit www.AcudorAccessPanels.com

PROJECT DATA

Custom Sizes Available - Fast!

Scan or Click



To view Pricing and Additional Product Info.

PROJECT NAME :	QTY	W	H	OPTIONS
ARCHITECT :				
DEALER :				
CONTRACTOR :				
LOCATION :	SPECIAL INSTRUCTIONS :			
DATE :	SUBMITTAL APPROVAL : (signature or stamp)			
TAGGING INSTRUCTIONS :				

TELEPHONE:
1-888-622-8367
FAX:
1-888-626-2907



PO BOX 4668
PMB 76520
NEW YORK,
NEW YORK 10163-4668
US



WEBSITE:
www.AcudorAccessPanels.com
E-MAIL:
info@AcudorAccessPanels.com

GDD

GREASE DUCT ACCESS DOOR

MODEL NO.	PANEL OUTSIDE DIMENSION		PANEL HEIGHT	STUD HEIGHT	HOLE SIZE Inches (mm)		MTG STUDS (NUTS)
	A	B	C	D	E	F	
FGGD0712	10" (254mm)	15" (381mm)	.5" (13mm)	1" (25mm)	7" (178mm)	12" (305mm)	6
FGGD720	10" (254mm)	23" (584mm)	.5" (13mm)	1" (25mm)	7" (178mm)	20" (508mm)	10
FGGD1212	15" (381mm)	15" (381mm)	.5" (13mm)	1" (25mm)	12" (305mm)	12" (305mm)	8
FGGD1220	15" (381mm)	23" (584mm)	.5" (13mm)	1" (25mm)	12" (305mm)	20" (508mm)	14
FGGD1620	19" (483mm)	23" (584mm)	.5" (13mm)	1" (25mm)	16" (406mm)	20" (508mm)	16
FGGD2020	23" (584mm)	23" (584mm)	.5" (13mm)	1" (25mm)	20" (508mm)	20" (508mm)	16

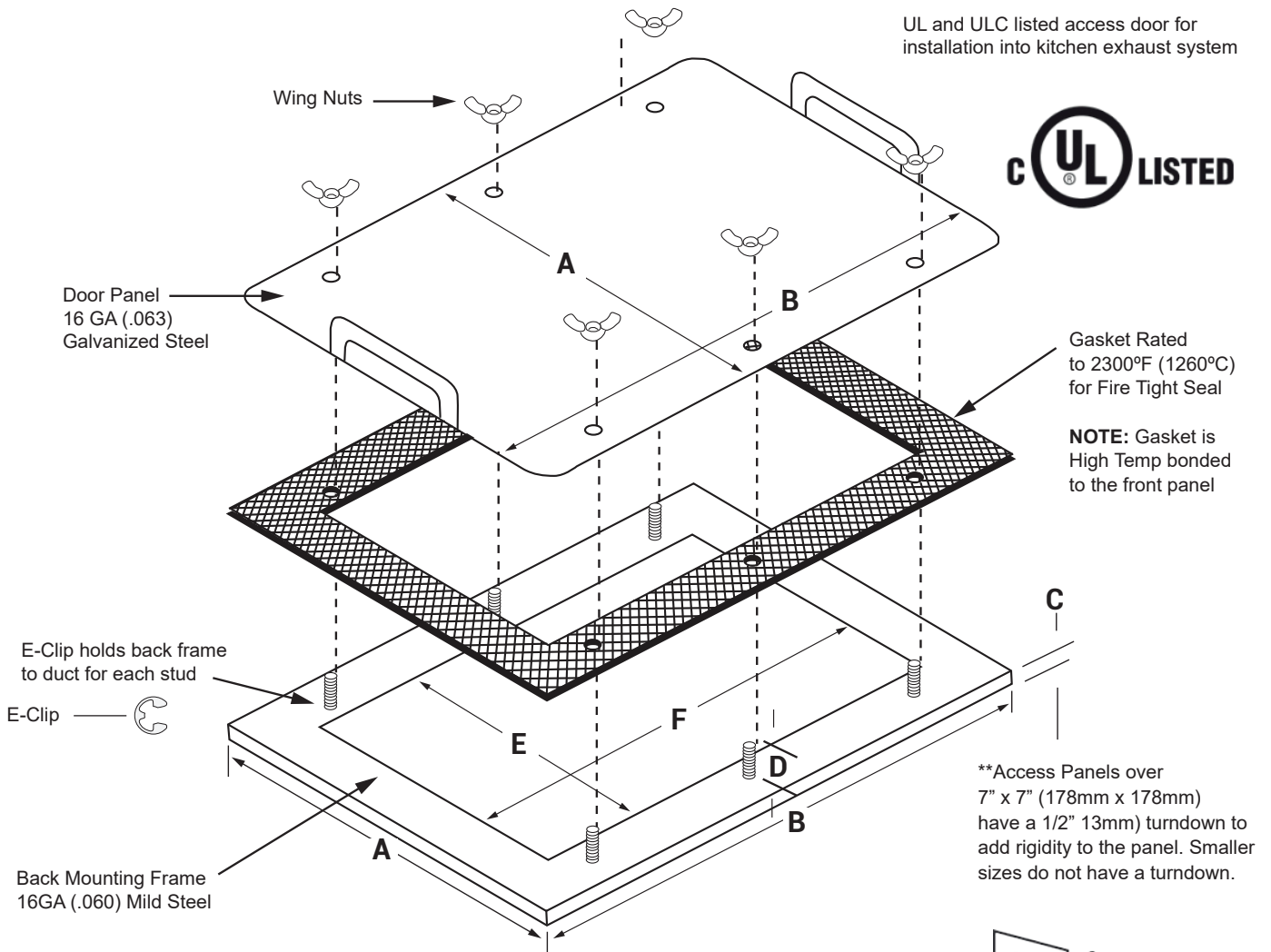

**Access Panels over 7" x 7" (178mm x 178mm) have a 1/2" 13mm) turndown to add rigidity to the panel. Smaller sizes do not have a turndown.

