

### APPLICATION

Designed for interior and exterior applications that require an access opening that will blend in with the surrounding floor material

### FEATURES

- Flush Diamond Plate door panel
- Door panel removable via screws

### SPECIFICATIONS

**MATERIAL:** Aluminum

**DOOR:** 1/4" aluminum diamond plate reinforced for the live load of 150 lb/per sq. ft.

**FRAME:** 1" x 1" aluminum angle designed to be cast into concrete

**STANDARD LATCH:** Door panel is secured to frame with 1/4" x 1" flat head screws

**FINISH:** Mill finish

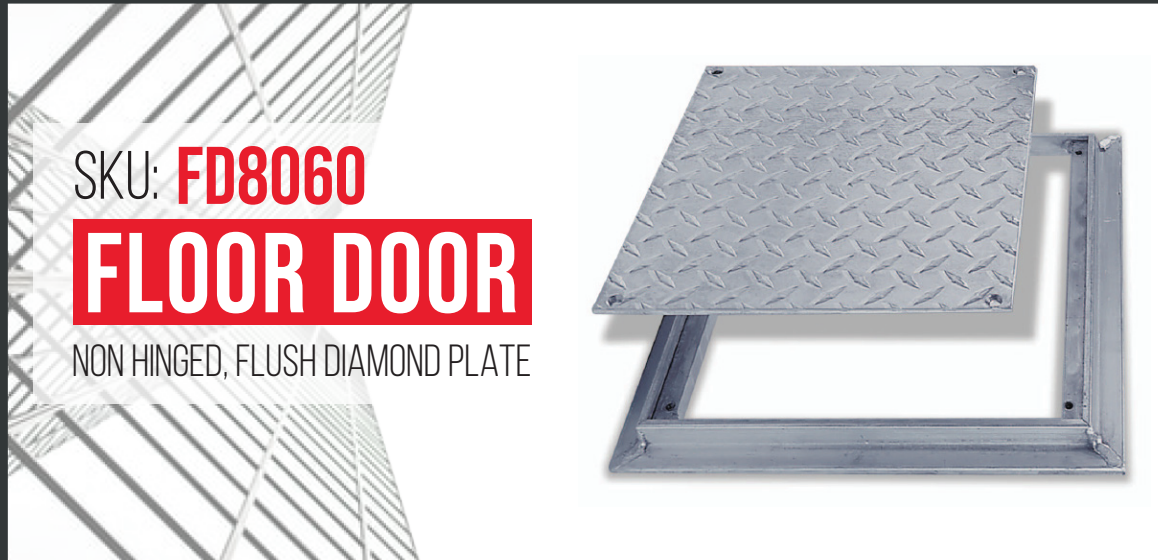

SKU: **FD8060**

**FLOOR DOOR**

NON HINGED, FLUSH DIAMOND PLATE

### DIMENSIONS AND APPEARANCE

>> CLICK TO VIEW ADDITIONAL DETAILS AND PRICING <<

#### STANDARD SIZES:

DOOR SIZE W x H		WEIGHT	
INCHES	(MM)	LBS	KG
8 x 8	(203 x 203)	4	1.8
12 x 12	(305 x 305)	6	2.7
18 x 18	(457 x 457)	12	5.5
24 x 24	(610 x 610)	24	10.9

For detailed specifications see submittal sheet

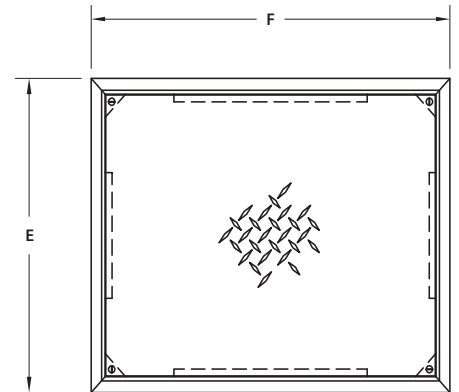

COVER & FRAME

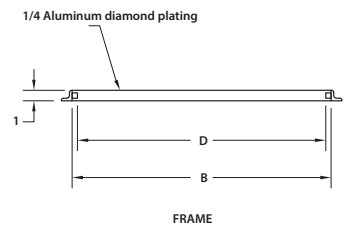
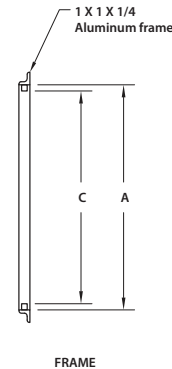
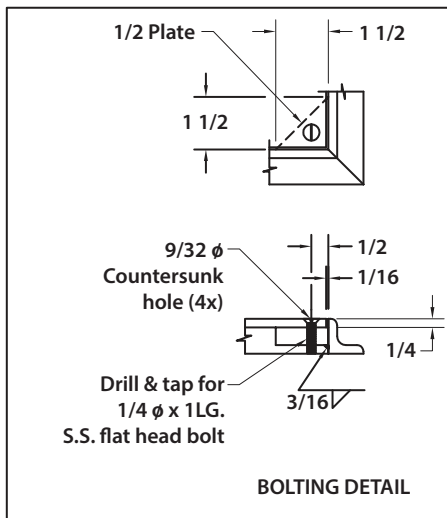

#### NOTES:

- MATERIAL: ALUMINUM
- LOADING: 150 LBS. PER SQ. FT.
- 316 STAINLESS STEEL NUTS & BOLTS



For a complete list of options visit [www.AcudorAccessPanels.com](http://www.AcudorAccessPanels.com)

Proprietary property of Acudor Products, Inc., sold and distributed with proper authorization

### PROJECT DATA

Custom Sizes Available - Fast!

PROJECT NAME :	QTY	W	H	OPTIONS
ARCHITECT :				
DEALER :				
CONTRACTOR :				
LOCATION :	SPECIAL INSTRUCTIONS :			
DATE :				
TAGGING INSTRUCTIONS :	SUBMITTAL APPROVAL : (signature or stamp)			

Scan or Click



To view Pricing and Additional Product Info.



TELEPHONE:  
1-888-622-8367  
FAX:  
1-888-626-2907



PO BOX 4668  
PMB 76520  
NEW YORK,  
NEW YORK 10163-4668  
US



WEBSITE:  
[www.AcudorAccessPanels.com](http://www.AcudorAccessPanels.com)  
E-MAIL:  
[info@AcudorAccessPanels.com](mailto:info@AcudorAccessPanels.com)

# FD8060

# NON-HINGED, FLUSH DIAMOND PLATE FLOOR DOOR

NOMINAL DOOR SIZE	FRAME OPENING		CLEAR OPENING		OVERALL SIZE		WEIGHT
in. (mm)	A in. (mm)	B in. (mm)	C in. (mm)	D in. (mm)	E in. (mm)	F in. (mm)	LBS. (KG)
8 x 8	8 (203)	8 (203)	7 (178)	7 (178)	10 (254)	10 (254)	4 (2)
12 x 12	12 (305)	12 (305)	22 (584)	22 (584)	14 (356)	14 (356)	6 (3)
18 x 18	18 (457)	18 (457)	22 (584)	22 (584)	20 (508)	20 (508)	12 (6)
24 x 24	24 (610)	24 (610)	28 (737)	28 (737)	26 (660)	26 (660)	24 (11)

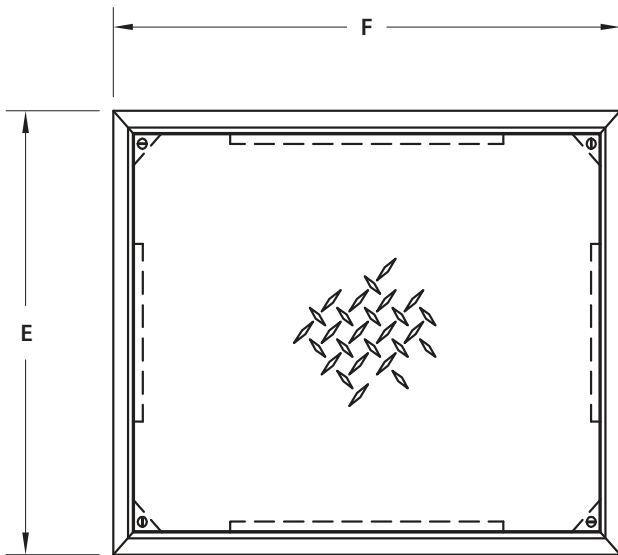

COVER & FRAME

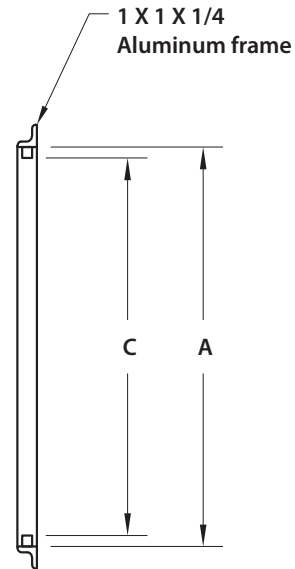

FRAME

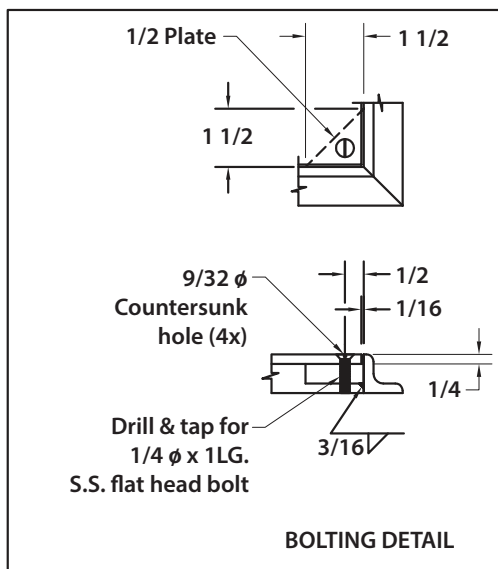

BOLTING DETAIL

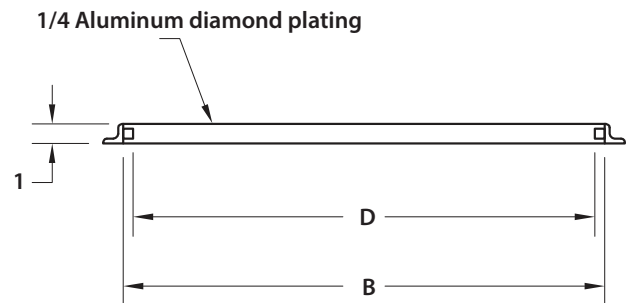

FRAME



NOTES:

- MATERIAL: ALUMINUM
- LOADING: 150 LBS. PER SQ. FT.
- 316 STAINLESS STEEL NUTS & BOLTS