

APPLICATION

This access door is ideal for use in laboratories, clean rooms, operating rooms, etc. where an airtight or watertight seal is required

FEATURES

- ADWT-PC is a flush access door that has been tested for air infiltration and water penetration
- Door and Frame fully welded
- Continuous Bulb Trim Gasket
- Continuous Stainless Steel Piano Hinge
- Air Infiltration : less than 0.01 cfm/sq foot – ASTM E 283
- Water Penetration : no leakage at 15.05 psf – ASTM E 331

SPECIFICATIONS

DOOR / DOOR FRAME: Flush to frame with reinforced edges

Stainless Steel or Steel: 16 gauge door; 16 gauge mounting frame

HINGE: Continuous exposed stainless steel piano hinge

GASKET: Continuous Bulb Trim Seal

STANDARD LATCH: Stainless Steel phillips head screws standard

OPTIONAL LATCHES/LOCKS: stainless steel allen head screws, stainless steel spanner head screws, torx, cylinder lock & key

FINISH: Steel: 5-stage iron phosphate preparation with prime coat of White alkyd baking enamel OR Stainless Steel: Type 304 - #4 satin polish



For a complete list of options visit www.AcudorAccessPanels.com



SKU: **ADWT-PC**
SPECIALTY DOORS
 AIRTIGHT/WATERTIGHT

DIMENSIONS AND APPEARANCE

>> CLICK TO VIEW ADDITIONAL DETAILS AND PRICING <<

STANDARD SIZES:

DOOR SIZE W x H INCHES (MM)	WEIGHT	
	LBS	KG
12 x 12 (305 x 305)	8	3.6
14 x 14 (355 x 355)	11	5
18 x 18 (457 x 457)	15	6.8
24 x 24 (610 x 610)	22	10
24 x 36 (610 x 914)	29	13.1
30 x 30 (762 x 762)	32	14.5
30 x 48 (762 x 1219)	44	20

Wall or ceiling opening is W + 3/8" (9 mm)
 For detailed specifications see submittal sheet

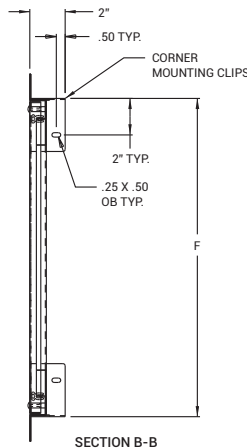
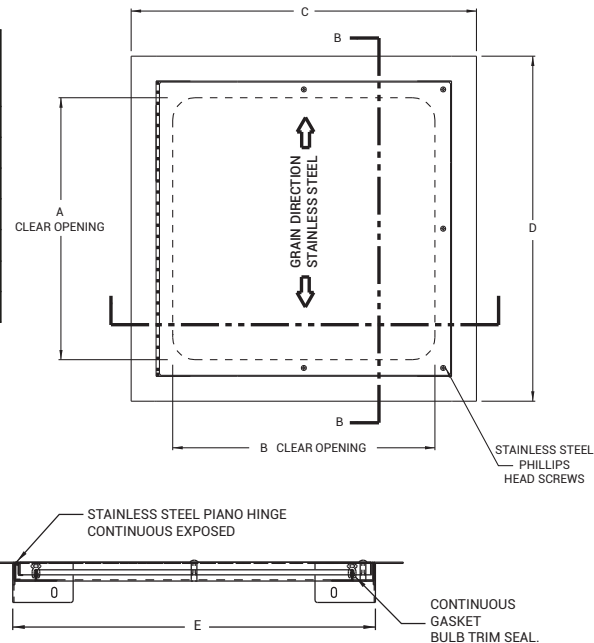

STANDARD FEATURES:
 FRAME FULLY WELDED TO PREVENT LEAKAGE.
 CONTINUOUS GASKET BULB TRIM SEAL.
 STAINLESS STEEL PHILLIPS HEAD SCREWS

Proprietary property of Acudor Products, Inc., sold and distributed with proper authorization

PROJECT DATA

Custom Sizes Available - Fast!

PROJECT NAME :	QTY	W	H	OPTIONS
ARCHITECT :				
DEALER :				
CONTRACTOR :				
LOCATION :	SPECIAL INSTRUCTIONS :			
DATE :				
TAGGING INSTRUCTIONS :	SUBMITTAL APPROVAL : (signature or stamp)			

Scan or Click



To view Pricing and Additional Product Info.

TELEPHONE:
1-888-622-8367
 FAX:
1-888-626-2907



PO BOX 4668
 PMB 76520
 NEW YORK,
 NEW YORK 10163-4668
 US



WEBSITE:
www.AcudorAccessPanels.com
 E-MAIL:
info@AcudorAccessPanels.com

ADWT-PC

SPECIALTY DOORS AIRTIGHT/WATERTIGHT

NOMINAL DOOR SIZE	A	B	C	D	E	F	SCREWS
in. (mm)							
12 x 12 (305 x 305)	9.65 (245)	9.65 (245)	14.75 (375)	14.75 (375)	12.00 (305)	12.00 (305)	2
14 x 14 (355 x 355)	11.65 (296)	11.65 (296)	16.75 (425)	16.75 (425)	14.00 (355)	14.00 (355)	2
18 x 18 (457 x 457)	15.65 (397)	15.65 (397)	20.75 (527)	20.75 (527)	18.00 (457)	18.00 (457)	2
24 x 24 (610 x 610)	21.65 (550)	21.65 (550)	26.75 (679)	26.75 (679)	24.00 (610)	24.00 (610)	2
24 x 36 (610 x 914)	33.65 (855)	21.65 (550)	26.75 (679)	38.75 (984)	24.00 (610)	36.00 (914)	3
30 x 30 (762 x 762)	27.65 (702)	27.65 (702)	32.75 (832)	32.75 (832)	30.00 (762)	30.00 (762)	5
30 x 48 (762 x 1219)	45.65 (1159)	27.65 (702)	32.75 (832)	50.75 (1289)	30.00 (762)	48.00 (1219)	5

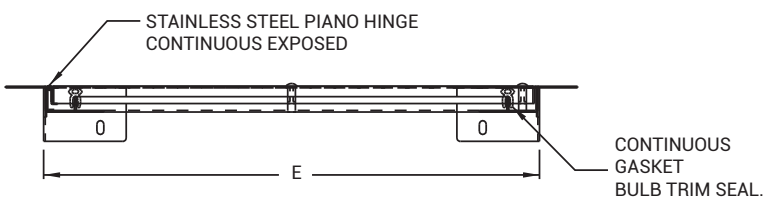
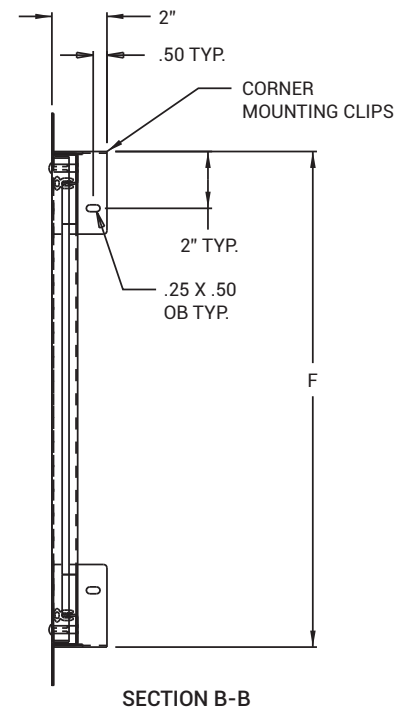
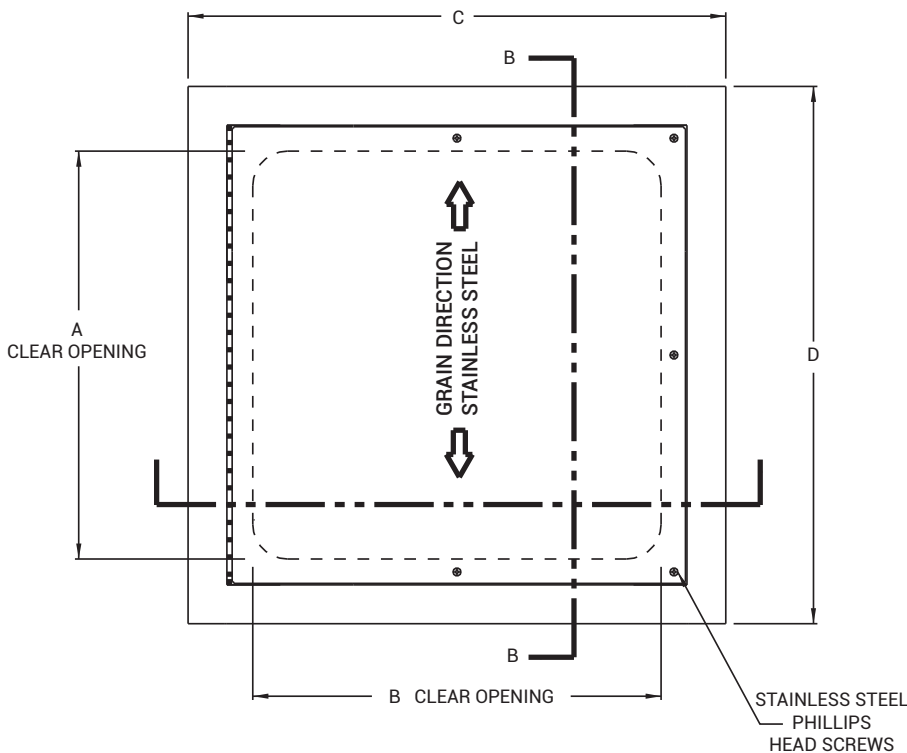

STANDARD FEATURES:
FRAME FULLY WELDED TO PREVENT LEAKAGE.
CONTINUOUS GASKET BULB TRIM SEAL.
STAINLESS STEEL PHILLIPS HEAD SCREWS